

ARMADILLO™ 500R

TECHNICAL MANUAL

Performance / Construction / Re-leveling / Safety



**Read this manual before installing your
ARMADILLO™ 500R**

www.armadillo-system.com

Printed on August 2017

GENERAL 4

SYSTEM OVERVIEW 4

KEY PERFORMANCES 4

 Strength 4

 Stiffness 4

 Thermal Efficiency 5

 Re-levelling 5

 Stackability 6

 Rapidly 6

 Eco-resilience 6

 Affordability 7

COMPLIANCE OF THE SYSTEM TO THE BUILDING REGULATIONS 7

 Clause B1 STRUCTURE 7

 Clause B2 DURABILITY 7

 Clause E2 EXTERNAL MOISTURE 7

 Clause H1 ENERGY EFFICIENCY 7

DESIGN 7

PEER REVIEW 7

NOTATION 7

ARMADILLO™ 500R 9

 ARMADILLO™ pod 500 10

 ARMADILLO™ Keystone 12

 ARMADILLO™ Jacking Pad 250 13

 ARMADILLO™ Thermal Base 14

Other components 14

 Concrete 14

 Steel 14

 Damp Proof Membrane (DPM) 14

LIMITATIONS 15

SITE WORKS: CONSTRUCTION 15

SITE WORKS: RE-LEVELLING 17

MAINTENANCE 18

 ARMADILLO™ Jacking Pad 250 18

 ARMADILLO™ Thermal Base 18

 Reinforced Concrete 18

SAFETY 19

DISCLAIMER 20

LIMITED WARRANTY 20

FREQUENTLY ASKED QUESTIONS 21

ENDNOTES 24

GENERAL

This Manual contains non-specific design information and installation procedures required for the ARMADILLO™ Foundation System.

SYSTEM OVERVIEW

The ARMADILLO™ 500R is a re-levelleable reinforced concrete Ribbed Biaxial Slab on ground.

The ARMADILLO™ 500R can be successfully used for buildings (dwellings, lightweight commercial, garages...) on soils prone to movement (e.g. liquefaction, expansive soils, organic soils...) and for all those structures (e.g. commercial, industrial...) that require a stiff base either piled or shallow.

Type of building	Re-levelleable	Piled ¹
Lightweight Housing	✓	
Lightweight Commercial	✓	✓
Commercial		✓
Industrial		✓

Table 1 – Conventional use of ARMADILLO™ 500R per type of building. With the name “Lightweight Housing” refers a stand-alone timber frame dwelling either with lightweight or heavy cladding and roofing; “Lightweight Commercial” refers to a small size single storey timber frame or steel structure building; with the name “Commercial” and “industrial” refer to any building with those uses.

The ARMADILLO™ foundation system can be either re-levelleable or not, the “R” suffix identifies the re-levelleable version.

Both the ARMADILLO™ 500R, and the ARMADILLO™ 500 consist of an 85 mm thick slab supported by a grid of ribs at 750 mm x 750 mm centres. Each rib is of trapezoidal section which an average width of 180 mm.

The overall foundation depth is 585 mm. External footings have an average width of 300 mm to provide for the extra load carried by these members.

Conventional timber or steel boxing is used to form the edge of the slab.

The ARMADILLO™ 500R includes bespoke elements to speed up the construction process, to ensure the highest thermal and to allow for future releveling.

KEY PERFORMANCES

Strength

The ARMADILLO™ 500R is **9 times stronger** than a conventional waffle slab.

The added strength of the ARMADILLO™ 500R is created by a unique and patented protected interweaving waffle slab design.

This unique design makes the foundation strong enough to withstand re-leveling at specifically formed jacking cavities created around the perimeter of the foundation and to accommodate large settlements of the ground without cracking.

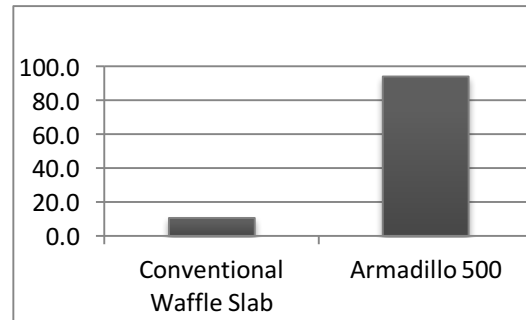

Figure 1- ARMADILLO™ 500R Vs Conventional Waffle Slab (305 mm height): Comparison between the Flexural Strength (as per NZS 3101:2006) y axis =φM(kNm/m)

Stiffness

A raft footing system which supports a superstructure that relies entirely on the footing system or on raft stiffness to prevent damage to the superstructure needs to be stiff enough to minimize its curvature.

This fact is particularly important on expansive soils or on ground that is prone to settlement.

The ARMADILLO™ 500R is **12 times stiffer** than a conventional waffle slab and it is able to accommodate large differential settlements without resulting damage to the superstructure.

The tolerable limits for relative differential movement depend on the shape of the construction, surface finish and the specific detail of the superstructure.

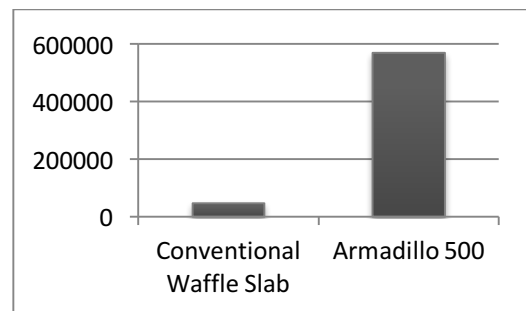

Figure 2 - ARMADILLO™ 500R Vs Conventional Waffle Slab (305 mm height): Comparison between Inertias y axis=J(mm4)

Thermal Efficiency

The ARMADILLO™ 500R thermal insulation performance is a new benchmark for the building sector.

In an ARMADILLO™ Foundation the heat flow by conduction is minimized and the radiance through the sealed air contained in the internal interweaving pattern of voids is highly reduced by the ARMADILLO™ Thermal base.

Wall Thickness mm	Floor Area Perimeter Ratio	ARMADILLO™ 500R R-Value (mK/W)	
		Thermal Base not installed	Thermal Base installed
100	1.5	1.32*	1.60*
	2.5	1.75*	2.07
	3.5	2.16	2.51
	4.5	2.56	2.92
150	1.5	1.41*	1.69*
	2.5	1.87*	2.19
	3.5	2.31	2.66
	4.5	2.73	3.09
200	1.5	1.48*	1.76*
	2.5	1.96	2.28
	3.5	2.43	2.78
	4.5	2.87	3.23
300	1.5	1.60*	1.88
	2.5	2.12	2.44
	3.5	2.62	2.97
	4.5	3.09	4.00

Table 2 - ARMADILLO™ 500R R-Values (with and without ARMADILLO™ Thermal Base installed). The ARMADILLO™ 500R that uses ARMADILLO™ pods 500C has the ARMADILLO™ Thermal Base included as a standard. (*) Configurations not compatible with in-floor heating.

Re-levelling

The ARMADILLO™ 500R being equipped with in-built jacking locations facilitates ease of re-levelling from the slab perimeter with conventional methods.

The ARMADILLO™ 500R is not only compliant but exceeds the requirements documented in the MBIE Guidance (Section 15.4.8):

1. The application of ARMADILLO™ 500R is NOT limited to sites where less than 100 mm SLS settlement is expected (calculated over the upper 10 m of the soil profile), in fact:
 - a. The jacks to lift the house are used only in case of need and through a jack and pack procedure they can recover any settlement
 - b. The ARMADILLO™ 500R is strong and stiff enough to accommodate settlements of 250 mm index 10 m SLS (two-storey light-framed buildings with heavy-weight roof and light-weight claddings) and 125 mm index 10 m SLS (two-storey light-framed buildings with heavy-weight and heavy-weight claddings) without cracking or deflecting out of the ranges specified in the MBIE guidelines documents.
2. The calculation is based on geotechnical reports compliant to the requirements for surface structures contained in MBIE section 15.4.7 (as amended).
3. The finished floor level can be 300 mm above adjacent ground or on sloping sites with a minimum of 250 mm and an average of 300 mm above adjacent G.L.
4. The ARMADILLO™ 500R is able to support a NZS 3604 superstructure with any type of roof and wall claddings, in fact:
 - a. The ARMADILLO™ 500R is strong enough to resist under heavy loads
 - b. The jacks to lift the house are used only in case of need and can be specifically chosen
 - c. The number and the layout of the lifting points is specifically designed with reference to the superstructure shape and weight

Relevelling Performance b. must be checked case by case in conjunction with the geotechnical engineer.

The ARMADILLO™ 500R can be used on sites where more than 100 mm SLS (index 10 m) settlement is expected under the premises of clause 15.3.8.2

5. Re-levelling is carried out with non-specialist equipment, techniques and materials. Conventional hydraulic jacks such as ENERPAC RC-506 or FPT CRM 50/200 can be used.

The ARMADILLO™ 500R meets the key performance expectations documented in the MBIE Guidance (Section 15.4.8):

1. The ARMADILLO™ 500R can span between any temporary point load support during the re-levelling process. This will typically involve the use of the ARMADILLO™ Jacking Pads 250: suitably designed contrast plates to jack against during re-levelling.
2. The ARMADILLO™ 500R curvatures under differential ground settlement in the load condition of $G + 0.3Q$ are less than 1 in 400 for the case of no support over 4 m, and no more than 1 in 200 for the case of no support of a 2 m cantilever at the extremes of the floor.
3. The ARMADILLO™ 500R is readily re-levellable and can be lifted after any settlement event and again in subsequent events².
4. The re-levelling and repair (including any associated superstructure damage) can be completed within a 4-week period during which the occupants may have to be relocated.
5. No damage to services within ARMADILLO™ 500R and readily repairable at the outside of it following the earthquake and during the re-levelling process.
6. The ARMADILLO™ 500R provides sufficient resistance to lateral displacement of the foundation under earthquake ground shaking expected in an ultimate limit state design event.

The ARMADILLO™ 500R is the first engineered concrete slab that meets the key performance expectations documented in the MBIE Guidance “Repairing and rebuilding multi-unit residential buildings” (Part E Explanatory notes to Table 20.1) for concrete slab to be built on TC3:

7. The ARMADILLO™ 500R has sufficient strength to be relevelled

from the perimeter after future SLS earthquakes.

Stackability

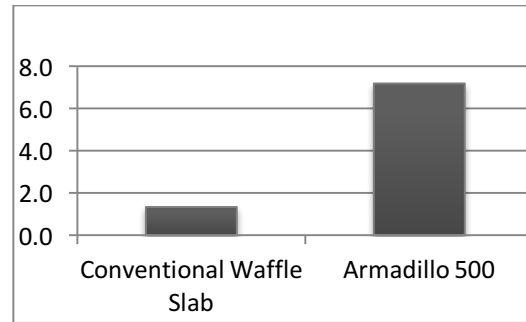

Figure 3 - ARMADILLO™ 500R Vs Conventional Waffle Slab (305 mm height): Comparison between the number of dwellings 200 m² to be built with a 40ft container of pods. Y axis = number of dwellings

The ARMADILLO™ pods 500 are designed to have an optimal stacking pitch and to consequently reduce freight costs and storage on site.

With the ARMADILLO™ pods 500 carried in a 40 ft container it is possible to build more than 6 houses³ instead of only one the same size that uses conventional polystyrene blocks.

Rapidity

The ARMADILLO™ Foundation System has been designed to speed up the construction process, saving labor costs and increasing productivity.

A regular shape foundation 150 m² generally requires less than 24 hrs. of work on site.⁴

The main features that make ARMADILLO™ Foundations easy to build are:

1. The builder does not need to measure the distance between the pods because the ARMADILLO™ pods 500 can be placed side by side to generate the pattern of interweaving ribs
2. The builder does not need to build stiffened members inside the slab
3. The builder does not need to tie most of the rebar because the ARMADILLO™ keystone is equipped with effective built-in retainers

Eco-resilience

The ARMADILLO™ Foundation System is the first building technology that offers, beside the conventional product line with pods made of recycled polypropylene (ARMADILLO™ pods 500P series), an ecofriendly and clever alternative to formwork derived from petrochemicals: the innovative ARMADILLO™ pods 500C series.

The ARMADILLO™ pods 500C are made with High Strength Pulp Molded Cardboard (HSC): a new generation 100% recycled natural material able to deliver extraordinary performance both in terms of strength and waterproofness.

HSC respects the environment because, to be produced, it does not consume a high quantity of energy, does not require catalyst agents or adhesives, does not generate a large quantity of CO₂ both during production and transport and when disposed of it does not generate toxic pollutants.

Affordability

The ARMADILLO™ 500R is a cost-effective re-levellable concrete slab and it represents a good alternative to the cases where ground improvement or deep piling works are required.

In particular cases the ARMADILLO™ technology can be combined with deep piles in order to contain their number and the construction costs, likewise with an ARMADILLO™ 500R it is possible to cut down the cost of ground improvement by limiting its extent to a strip around the foundation perimeter (instead of its full area).

COMPLIANCE OF THE SYSTEM TO THE BUILDING REGULATIONS

The ARMADILLO™ Foundation System if designed⁵, used, installed and maintained in accordance with the statements and conditions of this Technical Manual, will meet the following provisions of the NZBC:

Clause B1 STRUCTURE

The ARMADILLO™ Foundation System is a specifically designed structure.

It is under the responsibility of the engineer in charge of the design to comply with all the relevant clauses of the New Zealand Building Codes.

Clause B2 DURABILITY

The ARMADILLO™ Foundation System uses materials and construction methods, which ensure sufficient durability to satisfy the functional requirements of the NZBC throughout the 50-year design life.

Clause E2 EXTERNAL MOISTURE

The ARMADILLO™ 500R complies with clause E2 acceptable solutions in a similar manner to conventional footings of a waffle slab type.

The ARMADILLO™ 500R provides adequate resistance to the penetration and accumulation of moisture and this can be demonstrated using acceptable solutions.

A Damp Proof Membrane (DPM) in complying with E2/AS1 10.3.3 protects the slab from absorption and transmission of moisture at the interface with the soil.

Clause H1 ENERGY EFFICIENCY

The thermal efficiency of the ARMADILLO™ 500R, computed in accordance with the normative guidance NZS 4214:2006 is compliant to the requirements of the code "(H1.0 table 1) **R-Value > 1.3 m²K/W**. Where in-floor heating is used the NZBC requires (H1.0 table 2) a higher **R-Value > 1.9 m²K/W** for the floor."

DESIGN

The ARMADILLO™ foundation system is designed by Cresco Group – www.cresco-group.com or by BANG accredited engineers.

PEER REVIEW

The ARMADILLO™ foundation system design has been peer reviewed by:

CENTRAUS Limited (structural engineering and compliance with MBIE Guidelines) - <http://www.centraus.co.nz>

RUAMOKO Limited (shear design) - <http://www.ruamoko.co.nz>

ENGEO Incorporated (geotechnical engineering) - <http://www.engeo.com>

NOTATION

The ARMADILLO™ foundation system is named in the plans and the documents according to the following notation:

Armادillo™ $\frac{500R/P}{1\ 2\ 3}$

1. It specifies the depth (in mm) of the ARMADILLO™ Pod
2. "R" means "re-levellable version"; blank field means "not equipped for re-levelling"
3. "C" means Cardboard version for the ARMADILLO™ Pods; "P" means fiberglass reinforced polypropylene version for the ARMADILLO™ Pods; blank field means "pod material to be specified".

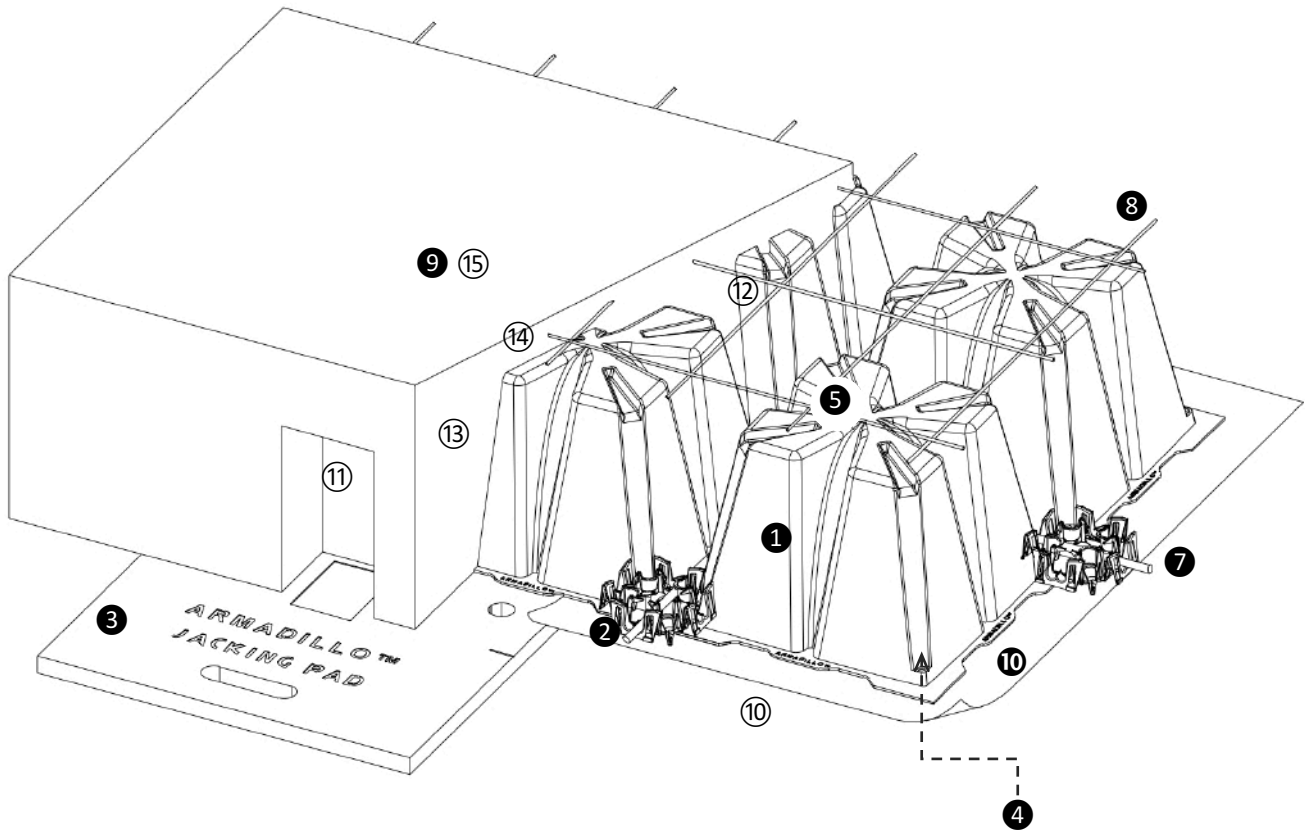

ARMADILLO™ Components:

- ① ARMADILLO™ pod 500
- ② ARMADILLO™ Keystone
- ③ ARMADILLO™ Jacking Pad 250
- ④ ARMADILLO™ Thermal Base

Other Components:

- ⑤ Steel mesh chair
- ⑦ Steel (rebar)
- ⑧ Steel (mesh)
- ⑨ Concrete
- ⑩ DPM

Notes:

- ⑩ Compacted ground
- ⑪ Cavity (jacking point)
- ⑫ Internal rib
- ⑬ External footing (foundation perimeter)
- ⑭ Slab
- ⑮ Top of Concrete

ARMADILLO™ pod 500

NZ Design n.418819
 NZ Pat. No. 625921
 PCT/NZ2014/000108

- ① Slot for the ARMADILLO™ Keystone
- ② Area to place steel mesh chairs
- ③ Spacing and stabilizing flaps
- ④ Antiskid Surface

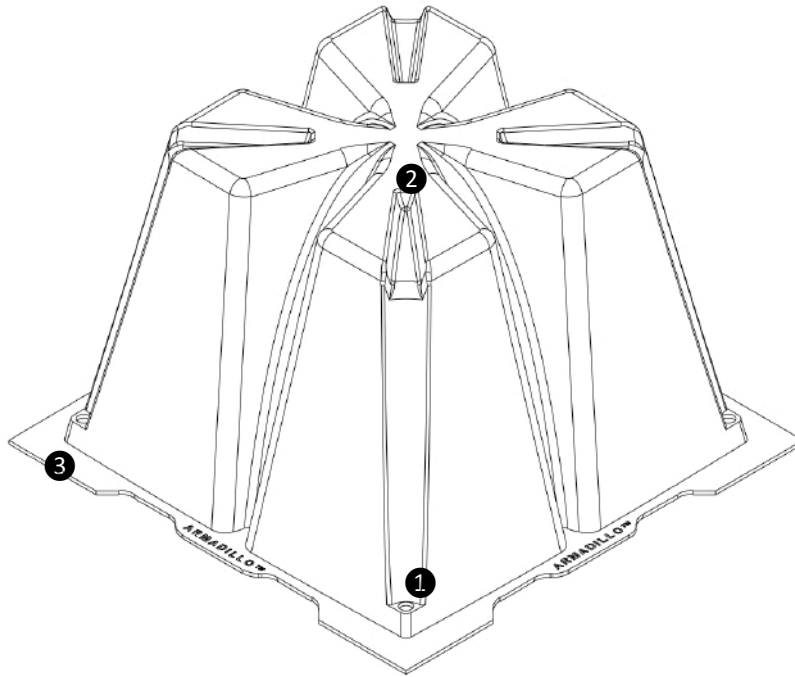

ARMADILLO™ pod 500C

The ARMADILLO™ pod 500C is designed in New Zealand and manufactured in China

(NOT AVAILABLE)

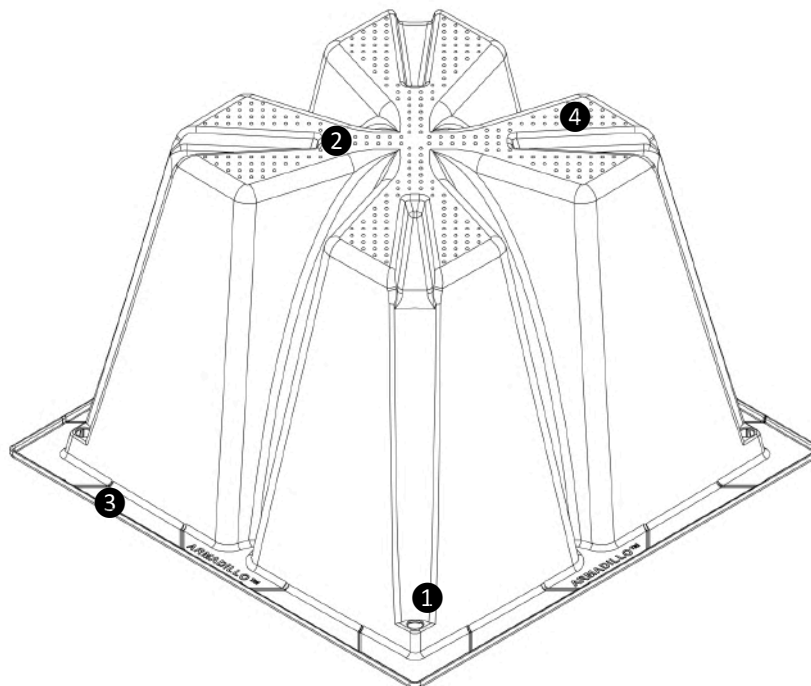

ARMADILLO™ pod 500P

The ARMADILLO™ pod 500P is designed in Italy and manufactured in New Zealand

ARMADILLO™ pods 500 are available in two materials: (500C version) High Strength Cardboard (HSC), a cardboard obtained from a high pressure mold by using only recycled paper and cardboard with natural resins and the (500P version) 10% fiber glass reinforced Polypropylene an engineered plastic obtained from recycled sources.

ARMADILLO™ pods 500 are placed directly on a DPM membrane on leveled ground and are arranged in such a way as to form a foundation with a grid of reinforced concrete ribs and edge beams when concrete is placed onto them.

The ARMADILLO™ pods 500 are used as void formers while the concrete is curing. Once the concrete cures, the pods do not add to the structural performance.

Thanks to their design ARMADILLO™ pods 500 can be simply placed side by side to provide the right structural pattern.

At the perimeter of the slab the pods have to be placed as per engineering details in order to provide the right space for the external footings.

ARMADILLO™ pods 500 can be easily stacked, handled and stored.

Compliance of the product to the Building Regulations

ARMADILLO™ pods 500 have been designed to bear the load of an operator (120 kg max) standing on top of them and to resist in wet conditions during the curing phase of the concrete.

ARMADILLO™ pods 500 are sacrificial formworks without any relevant performance once the concrete has cured, therefore, even though when placed in a dry and confined space the HSC is very durable, they don't need to comply with any requirements of durability.

Installation

ARMADILLO™ pods 500 have to be placed on a DPM membrane on levelled ground according to engineering drawing layout.

During the installation the operators (max weight 120 kg) can walk on top of the ARMADILLO™ pods 500.

After the set up the ARMADILLO™ pods 500C must be protected with a water proof membrane (e.g. a polyethylene sheet) to avoid the pods being exposed to rain if construction works is delayed.

In any case it is not recommended to place ARMADILLO™ pods 500C if there is a risk of

heavy rain. If the ARMADILLO™ pods 500C do accidentally get wet they need to dry and be checked before being used as formwork or before walking on top.

The ARMADILLO™ pods 500C must be used together with the ARMADILLO™ Thermal bases.

The ARMADILLO™ pods 500P can be placed and used in any weather conditions, with or without thermal bases.

Once correctly placed the ARMADILLO™ pods 500 have to be interlocked with the ARMADILLO™ Keystones and before the pouring phase all the rebar (deformed steel and steel mesh) has to be set up according to the engineering plans.

The deformed steel bars of the internal ribs can be placed and retained (without tying them) by the ARMADILLO™ Keystones. The deformed steel bars of the external footings have to be placed and adequately tied by using conventional spacers and chairs as well as the steel mesh.

Thanks to their design the ARMADILLO™ 500 pods, once interlocked with the ARMADILLO™ Keystones and the rebar will not move or float during the pouring of the concrete. However, care must be taken to the whole structure evenly and avoid build-up of concrete in any part of the foundation. Please follow the specific pouring instructions in this manual.

Handling and Storage

Handling and storage on site is under the control of the installer.

The installer is responsible for checking the integrity of the product on receipt, and form then is responsible for maintaining it and avoiding shocks and stresses to the product.

Clean and dry storage out of direct sunlight must be provided for the product.

For further details please refer to the product Safety Data Sheet.

Technical data

Material = High Strength Cardboard (500C) /
Fiberglass reinforced polypropylene (500P)

L x L x Height = 750 x 750 x 500 mm

Volume ≈ 150 l

Weight ≈ 5,0 kg (500C) ; 4,5 kg (500P)

Maximum weight on top (worker) = 120 kg

Consumption of concrete = 0,32 m³/m²

Number of pieces per pallet = 30 pcs.

ARMADILLO™ Keystone

NZ Pat. Appl. No. 625921
PCT/NZ2014/000108

- ① Built-in rebar retainers
- ② Pin (to be inserted into the ARMADILLO™ 500R pods slots)

The ARMADILLO™ Keystone is designed and manufactured in New Zealand

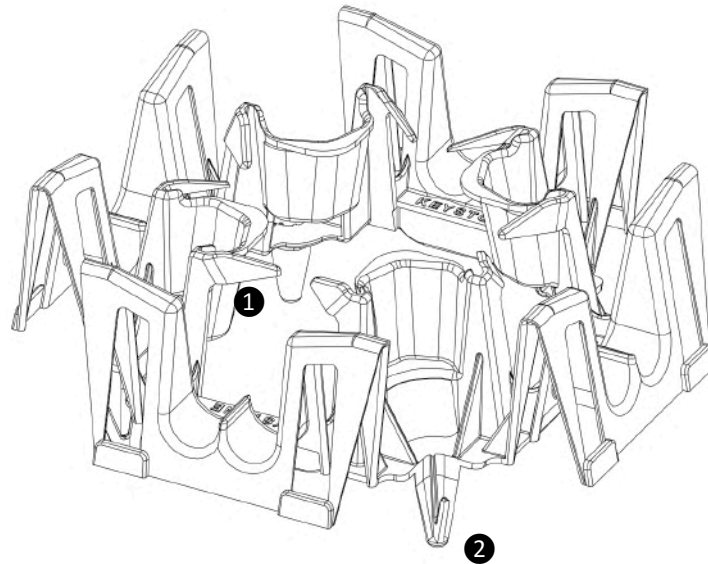

ARMADILLO™ Foundation System HSC pods are interlocked at every corner by using a Re-milled Black Polypropylene keystone.

The ARMADILLO™ keystone has been designed to be perfectly ergonomic and to ensure an adequate concrete cover and an effective retaining for the rebar.

The ARMADILLO™ keystones are stackable.

The deformed steel bars can drop into the ARMADILLO™ Keystones from a height of 600 mm and can be eventually adjusted sliding after positioning.

Installation

The ARMADILLO™ keystones must be placed at every corner of the ARMADILLO™ pods 500 ensuring the pin is placed through the bespoke slot on the pod.

An effective link is obtained only when each pin has been fully interested in its slot.

Handling and Storage

Handling and storage on site is under the control of the installer.

The installer is responsible to check the integrity of the product on receipt, and for

then is responsible for maintaining it and avoiding shocks and stresses to the product.

Clean and dry storage out of direct sunlight must be provided for the product.

For further details please refer to the product Safety Data Sheet.

Technical data

L x L x Height = 220 x 220 x 120 mm
 Weight ≈ N.A.
 Material = Re-milled Black Polypropylene
 Maximum number of bars = 2 in each direction
 Maximum diameter of bars = 20 mm
 Minimum diameter of bars = 12 mm
 Bottom spacing for cover = 50 mm
 Lateral spacing for cover = 35 mm
 Force to be applied to extract a bar = N.A. (D20); N.A. (D12)
 Concrete cover = 50 mm (DPM side); 35 mm (Internal protected void side)
 Number of pieces per package = 20

ARMADILLO™ Jacking Pad 250

NZ Pat. Appl. No. 618663

- ① Retaining Slot
- ② Handle
- ③ Marking line (external side of the external footings)
- ④ Jacking point

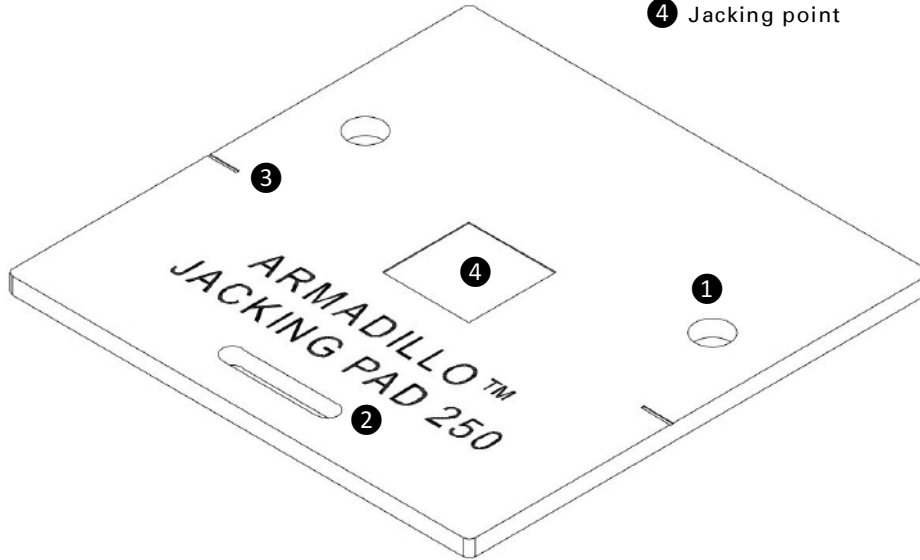

The ARMADILLO™ Jacking Pad 250 is designed in Italy and Made in China

ARMADILLO™ Jacking Pads 250 are 800 mm x 800 mm x 40 mm high plates made from Ultra High Molecular Weight Polyethylene (UHMWPE) and designed to be used as support for the jacks during releveling.

The ARMADILLO™ Jacking Pads 250 are placed under the DPM, directly on levelled ground under the external footings of the slab (to be directly poured on top of them).

The ARMADILLO™ Jacking Pads 250 have been designed to be easily handled on site and horizontally joined to the concrete once the concrete of the external footings of the slab has cured.

Compliance of the product to the Building Regulations

The material used for ARMADILLO™ Jacking Pads 250 (UHMWPE) ensures sufficient durability to satisfy the functional requirements of the NZBC throughout the 50 year design life under the provisions of this Technical Manual.

Installation

The ARMADILLO™ Jacking Pads 250 must be installed according to engineering layout and details.

They must be placed on even and horizontal well compacted ground / gravel raft. Do not place the ARMADILLO™ Jacking Pads 250 upon the sand blinding layer.

The ARMADILLO™ Jacking Pads have to be placed under the DPM (when applicable).

Handling and Storage

The ARMADILLO™ Jacking Pads 250 are equipped with a built in handle for easy handling on site.

Handling and storage on site is under the control of the installer.

The installer is responsible to check the integrity of the product on receipt, and for then is responsible for maintaining it and avoiding shocks and stresses to the product.

Clean and dry storage out of direct sunlight must be provided for the product.

For further details please refer to the product Safety Data Sheet.

Technical data

L x L x Thickness = 800 x 800 x 40 mm

Weight ≈ 25 kg

Material = Ultra High Molecular Weight Polyethylene (UHMWPE)

Bearing capacity = 250 kN (footprint 150 x 150 mm)

Number of pieces per package = upon request

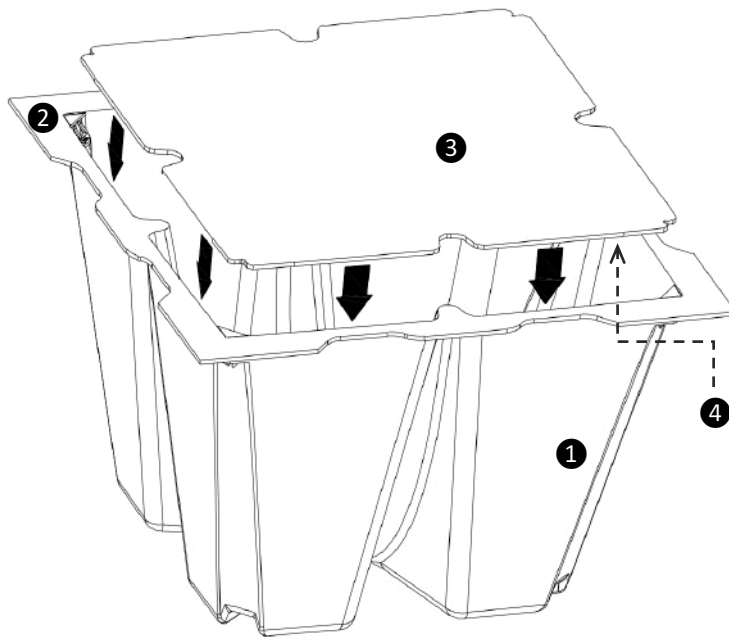
ARMADILLO™ Thermal Base

- ① Armadillo™ Pod 500
- ② Built-in clips
- ③ Armadillo™ Thermal Base
- ④ Reflective side

The ARMADILLO™ Thermal Base is designed in New Zealand and manufactured in China

The ARMADILLO™ Thermal Base has to be assembled with every ARMADILLO™ pod 500C. An incorrect installation of the Thermal Base might cause a collapse of the ARMADILLO™ pod 500C with the pressure of the wet concrete.



The ARMADILLO™ Foundation System includes the ARMADILLO™ Thermal Base, a PVC board laminated with a Metalized PET membrane. The ARMADILLO™ Thermal Base, taking advantage of the in-slab air cavities is able to effectively reflect heat, insulate the building and minimize power consumption. The Metalized PET membrane is the same material used in aerospace field and for survival thermal blankets (often known by one of its trade names: Mylar®).

Compliance of the product to the Building Regulations

The ARMADILLO™ Thermal Base is being compliant with the NZS 3604:2011 requirements and ensures sufficient durability to satisfy the functional requirements of the NZBC throughout the 50 year design life under the provisions of this Technical manual.

Installation

ARMADILLO™ Thermal Base has to be assembled together with the ARMADILLO™ pod 500 so that the reflective side faces the interior of the pod.

If needed the installer has to clean the reflective side of the ARMADILLO™ Thermal Base before installing.

The ARMADILLO™ Thermal Base has to be properly locked with the clips built-in at corners of the ARMADILLO™ pod 500.

The Thermal Base provides additional strength to the ARMADILLO™ 500C pod preventing the risk of collapsing with the wet concrete pressure.

Handling and Storage

Handling and storage on site is under the control of the installer.

The installer is responsible to check the integrity of the product on receipt, and for then is responsible for maintaining it and avoiding shocks and stresses to the product.

Clean and dry storage out of direct sunlight must be provided for the product.

Avoid storing items on top that may puncture or scratch the material.

For further details please refer to the product Safety Data Sheet.

Technical data

L x L x Thickness = 630 x 630 x 6 mm

Weight ≈ 1,6 kg

Material = Metalized PET on PVC foam board

Thermal Emittance = 0,10

Number of pieces per package = 30

Other components

Concrete

Concrete mix design prescribes a type of cement according to the requirement of the environmental conditions at low free water/cement ratio with common additives like plasticizer and retarder. Final proportions of the detailed concrete mix design will be issued by the specialized Supplier to obtain concrete of homogeneous structure which when cured will have the required strength, density, resistance to weathering and water tightness (water absorption and water penetration). The grade of the concrete must be at least $f_c = 25$ MPa (or higher according to the engineering plans and calculation notes). The concrete shall conform to NZS 3144:1987: F1: concealed works, F5: exposed edge of foundation, U3: floor slab and all local regulations. The foundation to be poured monolithically generally in a sequence of 3 layers without exceeding 100 m² in each of them and with a maximum pouring rate of 18 m³/h. The concrete must be vibrated only over (and over every) the ARMADILLO™ Keystones.

Steel

The reinforcing bars and all welded mesh fabric reinforcing shall conform to NZS 4671:2001 "Steel Reinforcing Materials. ARMADILLO™ Keystones are used to securely interlock ARMADILLO™ pods 500 together with the reinforcing steel bars until the concrete is placed. The reinforcing mesh is held in place by conventional mesh chairs. The steel grade and size depends on the engineering design and it is specified in the plans and in the calculation notes provided by the structural engineer.

Damp Proof Membrane (DPM)

A continuous damp proof membrane should be placed on top of the sand blinding (20 mm) layer over the entire slab area in accordance with NZS3604:2011. Where polyethylene sheet damp proof membrane is to be used the material should be not less than 0.25 mm thick, have a vapor flow resistance > 90 MN s/g, have lapped joints not less than 150 mm wide which are sealed with pressure sensitive plastic tape not less than 50 mm wide.

LIMITATIONS

Ultimate Bearing Capacity of the soil under the ARMADILLO™ Jacking Pads > 200 kPa*

(*) When used in combination with the ARMADILLO™ 500R foundation and for jacking forces above and beyond 50 kN.

Allowable Bearing Capacity of the soil under the footprint of the building > 50 kPa*

(*) Specifically designed engineered gravel raft required

Recommended maximum settlement of the soil in static conditions under the dwelling loads = 25 mm

The application of the Armadillo™ 500R is limited to sites where less than 250 mm SLS (two-storey light-framed buildings with heavy-weight roof and light-weight claddings) and 125 mm SLS (two-storey light-framed buildings with heavy-weight and heavy-weight claddings) settlement is expected (calculated over the upper 10 m of the soil profile).

Armadillo™ 500R is a foundation designed to support light-framed superstructures preferably (but not necessarily) using lightweight claddings and roofing.

The ARMADILLO™ 500R is a specifically designed structure. The aforementioned values are for reference only and they only apply to a foundation that needs to perform as re-levellable.

SITE WORKS: CONSTRUCTION

EARTHWORKS	Clear topsoil and form a level building platform (levels according to drawings, hardfill according to geotechnical engineer). Ensure or confirm the dependable bearing capacity required on foundation footprint plus a margin of 650 mm (or the depth of the hardfill whichever is greater). Cover building platform with 20 mm sand blinding (sand blinding NOT to be laid under the ARMADILLO™ Jacking Pads 250). Council might need to inspect site before slab construction commences.
INSPECTION	Engineer inspection (after topsoil cleared and before hardfill)
ARMADILLO™ JACKING PADS	Ensure or confirm the bearing capacity of the soil in correspondence of the ARMADILLO™ Jacking Pads 250. Should more accurate procedures are not available: exert a 80 kg load on a timber post 40x40 mm. No evident (1 mm depth max) footprint on the ground after loading is required. Place the ARMADILLO™ Jacking Pads 250 according to the engineering drawings layout and details. In case not differently specified on the plans the top level of the ARMADILLO™ Jacking Pads 250 coincides with the top level of the sand blinding.
DPM	Cover sand blinding with a DPM. Tape securely all the laps. Cut the DPM over the jacking point and retaining slots of the ARMADILLO™ Jacking Pads 250.
ARMADILLO™ THERMAL BASE <i>(Optional for the ARMADILLO™ pods 500P series)</i>	Assemble an ARMADILLO™ Thermal Base to the ARMADILLO™ pods 500 so that the reflective surface faces the inside of it. PLEASE NOTE: The ARMADILLO™ Thermal Base must be assembled to every pod when the ARMADILLO™ pods 500C are used. The ARMADILLO™ Thermal Base locks with a simple pressure on the built-in clips at the corners of the pods.
FORMWORK	Set out boxing (and rebate if needed) taking care to preplace the cavities for the jacking points according to the engineering drawings layout and details.
INSPECTION	Foundation positioning and levels to be certified by a land surveyor before pouring, it is recommended to organize the inspection at this stage.
ARMADILLO™ 500 PODS	Place ARMADILLO™ pods 500 by starting with four from an outer corner of the foundation. Lock these first pods with the ARMADILLO™ keystone. It is recommended to complete two orthogonal rows before proceeding with the installation and locking of all pods: in this way a check on the pods distribution will prevent mistakes. Place two adjacent pods, locking them with the keystone as well. Repeat this process for the rest of the foundation. Do NOT walk on wet ARMADILLO™ 500C pods.

- PLUMBING** Install the plumbing and any other services, in accordance with the drawings and the local codes. In order to accommodate the design settlements special precautions have to be taken at the interface between the urban sewerage infrastructure and the foundation embedded pipes (as reference: Expanda and Swivel Joints By Wallace Pumps may be used for the purpose). It is recommended to minimize (but it is allowed) the passage of the pipes inside the ribs. Additional reinforcement is needed in the ribs adjacent to the ones used for the pipes passage.
- REINFORCING BARS** Place reinforcing bars in the external footings and ribs according to the engineering drawings details being careful to ensure the steel in each rib is positioned in the lugs provided in the ARMADILLO™ keystones. The ARMADILLO™ keystone is provided with a bar retainer that prevents any undesirable movement of the rebar, therefore all the steel bars joined with the keystone don't need to be tied. Referring to the reinforcing of the ribs: All y direction bars have to placed first (y direction is preferably the shortest dimension of the foundation) to follow the bars in the orthogonal direction. Unless differently specified all XD12 Grade 500R laps must be 600 mm and all XD20 Grade 500R laps must be 1000 mm. Concrete cover must be strictly respected. Unless differently specified the concrete cover is: 50 mm from edges of concrete exposed to ground, 30 mm from top for wire mesh.
- REINFORCING MESH** Place reinforcing mesh on top of the ARMADILLO™ pods 500. Ensure a 50 mm gap to edge boxing. Use approved mesh chairs to ensure the required concrete cover. Lap and tie mesh. Tie reinforcing bar to perimeter mesh. Re-entrant corners and external footings need additional steel tied, refer to the engineering drawings layout and details.
- INSPECTION** Engineer and Council inspection.
- POURING** Pour internal and lateral thickenings and topping slab in one operation. The concrete cast has to generate a monolithic structure. For convenience it is easier to use a concrete pump. Pour the concrete so that layers about 200 mm thick are placed at every step. Do not exceed the maximum pouring rate of 18 m³/h. About three steps of casting are expected to completely fill of a standard size foundation (200 m²). The concrete must be vibrated close the external formwork (rather than close to the ARMADILLO™ 500 pods) and only over the ARMADILLO™ keystones. A wrong pouring procedure can cause damage to the formworks. **Do NOT pour on wet ARMADILLO™ 500C pods.**
- FINISHING** Finish surface and ensure adequate curing takes place in accordance with the good building practices. Preferably a DPM is placed on top of the slab immediately after pouring. Saw cut the slab surface for shrinkage control.

SITE WORKS: RE-LEVELLING

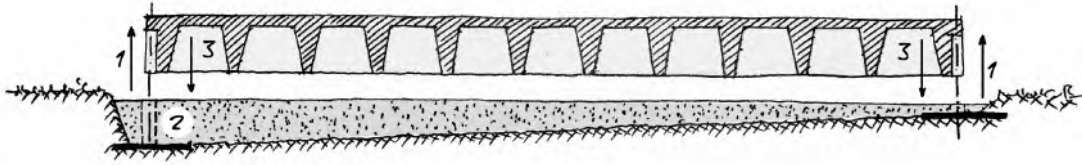

- LEVELS ASSESSMENT** Measure the floor levels over the jacking pad positions (lifting points). Locally excavate the jacking cavities around the foundation perimeter.
- PREPARATION** Check the maximum lifting force expected for the re-leveling (the value is indicated in the calculation note) and equip the site with suitable jacks. Carefully clean the surface of the jacking pads and place the jacks in the cavities. Remove all possible loads inside the house and secure unstable objects (please note: **NO** elements of the super-structure need to be removed, including heavy weight cladding and heavy roof tiles if present). Depending on the required lifting height to be reached, temporary disconnect the drainage system.
- (1) LIFTING** A minimum loading footprint has to be ensured both on top of the ARMADILLO™ Jacking Pads and under the top of the cavities. Use 1+1 steel plates 150x150x15thk. mm for this purpose.
Proceed with the lifting. The lifting procedure can be carried out both with mechanical or with hydraulic jacks. Preferably use a hydraulic circuit equipped with independent pressure valves on groups of four cylinders maximum. During this phase the operators have to constantly check the levels of the foundation and the pressure of the circuit / pressure of each jack. By acting on the valves (or manually on the mechanical jacks), the operators must ensure that for every lifting point the jacks are adequately working: 1) in case of manual procedure, increase the force acting in each jack in steps of 50 kN. All the jacks have to be loaded before starting with a new load step 2) set as a target force the maximum expected value indicated in the calculation note 3) In any case, limit the lifting force of the jacks to 250 kN. Unless differently specified every jacking point must be used.
This phase might require a jack and pack iterative procedure
- LOCKING** Once the dwelling is re-leveled and it has been raised at the desired height, pack on either side of each jack cavity in the space between the bottom of the external footing and the ARMADILLO™ Jacking Pads. The pack can sit on the pads (both sides of the jacking cavities).
- (2) GROUTING** Grout under the foundation in order to create a new planar surface at the right level. A high-flowable/low-strength concrete is suitable for the purpose (for reference Mapegrout Compact Fill can be used). The jacking cavities must be protected to be re-used in case of future needs.
- (3) LOWERING** Once the grout has cured (consult the grout technical manual) the dwelling can be lowered on top. All the precautions described for the lifting phase have to be taken into account. Re-connect the drainage system if necessary.



The ARMADILLO™ 500R has been expressly designed to be re-levelleable, nonetheless an incorrect lifting procedure can cause **severe damage** to the foundation structure.

MAINTENANCE

The ARMADILLO™ Foundation System uses materials and construction methods which ensure sufficient durability to satisfy the functional requirements of the NZBC throughout the 50 year design life, nonetheless appropriate maintenance is recommended.

This chapter describes the actions to be performed in order to preserve the structure from deterioration.

No maintenance is required for the products ARMADILLO™ pods 500 and ARMADILLO™ Keystone once installed.

ARMADILLO™ Jacking Pad 250

In the absence of a severe seismic event and until the product remains fully buried into the ground no maintenance is required.

After a severe seismic event the planarity and the position of the ARMADILLO™ Jacking Pads 250 should be checked and possibly restored.

When the ARMADILLO™ Jacking Pads 250 remain exposed to environmental stresses (e.g. extended exposure to UV) or loading stresses (e.g. after a jacking) they need to be visually inspected (color, integrity, planarity) in order to confirm their performance and possibly substituted.

ARMADILLO™ Thermal Base

Until the product remains assembled together with the ARMADILLO™ pod 500 no maintenance is required.

The ARMADILLO™ Thermal Base is designed to remain attached to the foundation, nonetheless, during re-levelling works the flowable concrete fill has to be poured and vibrated with care avoiding that its level does not result higher than 40 mm from the bottom of the ribs.

Reinforced Concrete

The performance of any concrete structure, likewise ARMADILLO™ Foundation, depends on the quality of the concrete mix (also referred to the specific environmental conditions) and of the works carried out on site.

Inspections by geotechnical and structural engineers and trials on construction materials have to be scheduled during the works in order to check their quality.

Any reinforced concrete structure should be periodically (at least every five years) inspected in all the surfaces that are exposed to ground, water or air.

The scope of these inspections is to detect the most common problems the concrete may incur:

1. Cracking
2. Impact Damage
3. Water absorption
4. Carbonation
5. Corrosion by chlorides
6. Alkali silica reaction
7. Sulphates attack

The premature failure of corroded steel reinforcing and the expansion of the iron corrosion products around the rebar are amongst the main causes of the concrete degradation.

Once one of the aforementioned problems is detected specific repairs have to be carried out.

SAFETY

The ARMADILLO™ Foundation System does not include any dangerous products.

No specific safety precautions are required for handling and storage.

During construction the ARMADILLO™ Foundation System requires the same safety precautions as any other construction of a reinforced concrete shallow foundation.

During re-levelling works additional and specific precautions have to be taken and only specialized workers and tested equipment must be involved.

Below are some specific risks to be considered (additional risks can occur and they need to be evaluated by a safety manager).



CONSTRUCTION WORKS

- Tripping hazard on top of the ARMADILLO™ 500 pods.
- Tripping hazard on top of the steel mesh.
- Do not walk on top of non-integral pods (drilled, cut, damaged).
- Do not walk on top of wet pods.



CONSTRUCTION WORKS

- Slipping hazard on top of wet ARMADILLO™ 500 pods.
- High risk of slipping on top of the ARMADILLO™ Jacking Pads 250.



RE-LEVELLING WORKS

- Suspended heavy loads hazard.
- Do not go under the suspended foundation.
- Parts of the superstructure might be unstable and fall during the re-levelling.
- During the lifting/lowering, place a safety pack under the foundation every 600 mm.
- Pack on both sides of the jacking point and only on top of the ARMADILLO™ jacking pads 250.



RE-LEVELLING WORKS

- Crushing hands hazard.
- Do not put hands or parts of the body under the suspended foundation.
- Do not put hands under the ARMADILLO™ jacking pads 250 during the re-levelling works.



RE-LEVELLING WORKS

- The use of untested equipment might be dangerous.
- Structural collapse hazard in case of inappropriate re-levelling.

DISCLAIMER

Information has been carefully checked and is believed to be accurate; however, no responsibility is assumed for inaccuracies.

Bang Ltd. reserves the right to make changes without further notice to any products to improve reliability, function, or design. Bang Ltd. does not assume any liability arising out of the application or use of any product; neither does it convey any license under its patent rights of others.

LIMITED WARRANTY

By taking delivery of the goods the Customer is deemed to have accepted the goods.

Bang Ltd. warrants only to the purchaser of the Bang Ltd. (the "Customer") that the product purchased from Bang Ltd. (the "Product") will be free from defects in materials and workmanship under the normal use for which the Product was designed for a period of 20 days on site.

Customer's exclusive remedy under this Limited Warranty shall be the repair or replacement, at Company's sole option, of the Product, or any part of the Product, determined by Bang Ltd. to be defective. In order to exercise its warranty rights, Customer must notify Company in accordance with the instructions described under the heading "Obtaining Warranty Service".

This Limited Warranty does not extend to any Product damaged by reason of alteration, accident, abuse, neglect or misuse or improper or inadequate handling; improper or inadequate wiring utilized or installed in connection with the Product; installation, operation or use of the Product not made in strict accordance with the specifications and written instructions provided by Bang Ltd. or approved engineers of Bang Ltd.; use of the Product for any purpose other than those for which it was designed; ordinary wear and tear; disasters or Acts of God; unauthorized attachments, alterations or modifications to the Product; the misuse or failure of any item or equipment connected to the Product not supplied by Bang Ltd. or designed by engineers not approved by Bang Ltd.; improper maintenance or repair of the Product; or any other reason or event not caused by Bang Ltd.

BANG LTD. HEREBY DISCLAIMS ALL OTHER WARRANTIES, WHETHER WRITTEN OR ORAL, EXPRESS OR IMPLIED BY LAW OR OTHERWISE, INCLUDING WITHOUT LIMITATION, ANY WARRANTIES OF MERCHANTABILITY OR FITNESS FOR ANY PARTICULAR PURPOSE. CUSTOMER'S SOLE REMEDY FOR ANY DEFECTIVE PRODUCT WILL BE AS STATED ABOVE, AND IN NO EVENT WILL BANG LTD. BE LIABLE FOR INCIDENTAL, CONSEQUENTIAL, SPECIAL OR INDIRECT DAMAGES IN CONNECTION WITH THE PRODUCT.

This Limited Warranty shall be void if the Customer fails to comply with all of the terms set forth in this Limited Warranty. This Limited Warranty is the sole warranty offered by Bang Ltd. with respect to the Product. Bang Ltd. does not assume any other liability in connection with the sale of the Product. No representative of Bang Ltd. is authorized to extend this Limited Warranty or to change it in any manner whatsoever. No warranty applies to any party other than the original Customer.

Bang Ltd. and its directors, officers, employees, subsidiaries and affiliates shall not be liable for any damages arising from any loss of equipment, loss or distortion of data, loss of time, loss or destruction of software or other property, loss of production or profits, overhead costs, claims of third parties, labor or materials, penalties or liquidated damages or punitive damages, whatsoever, whether based upon breach of warranty, breach of contract, negligence, strict liability or any other legal theory, or other losses or expenses incurred by the Customer or any third party.

FREQUENTLY ASKED QUESTIONS

Q: I read ARMADILLO™ 500R (with the ARMADILLO™ pod 500C series) uses a material called "HSC" what is it?

A: HSC is an acronym for High Strength Cardboard. HSC is created by pressure molding of a controlled mix of recycled brown Kraft papers admixed with a special formula of natural resins to provide extra strength and waterproofing.

Q: Does the cardboard deteriorate over the time?

A: The HSC contains a natural waterproofing additive and its special formula has been studied to be very durable, nonetheless in this application the durability of the cardboard once the concrete has cured is irrelevant because it is a sacrificial formwork whose integrity over the time does not prejudice the structural performance of the foundation.

Q: What happens in case insects or rodents attacked the cardboard?

A: There is no evidence of the outcome of attacks to the HSC, nonetheless in this application the HSC is used to make sacrificial formwork whose integrity over the time does not prejudice the structural performance of the foundation.

Q: I read that the ARMADILLO™ 500R is a very strong foundation, how can it be so robust by using cardboard?

A: It is the special shape (and not the material) of the ARMADILLO™ 500 pods that generates the special interwoven pattern of reinforced ribs on which the strength and stiffness of the structure depend.

Q: Does the cardboard of the pods degrade if exposed to rain?

A: The HSC has waterproofing performances and once dried it restores its strength without degrading. To prevent risks associated with heavy rain (and simply to avoid the time to make it dry) it is recommended to always protect the ARMADILLO™ 500 pods with a DPM against the rain.

Q: Does the cardboard of the pods degrade with the moisture of the wet concrete?

A: The HSC has been designed and tested to resist the moisture of the wet concrete without degrading.

Q: How do you prevent from floating the pods when the concrete is poured?

A: The ARMADILLO™ pods and the ARMADILLO™ keystones combined with the rebar and the steel mesh are specifically designed for this purpose.

Q: Because the ARMADILLO™ 500R is re-levelleable foundation does it mean I can place it on every kind of soil?

A: The ARMADILLO™ 500R suits most soils and can be re-levelleable in case of settlements. It is recommended to carry out ground improvement or deep foundation works on soils that might incur settlement in static conditions in order to prevent frequent re-levelling.

Q: May I build an ARMADILLO™ 500R foundation without a specific design?

A: No, the ARMADILLO™ 500R foundation requires a specific design.

Q: I read the ARMADILLO™ 500R foundation needs to be designed or peer review by Cresco Group, is it correct?

A: Yes, it is correct. The ARMADILLO™ 500R is a new foundation system that includes bespoke elements and requires a specific know-how. Cresco Group being the inventor can guarantee the best performance of the foundation system and prevent the unexpected.

Q: What is Cresco?

A: Cresco is a leading boutique engineering firm with offices in Europe and in New Zealand. Through the years Cresco has worked for major projects (residential, commercial, nuclear power stations, conventional power plants, hydropower plants, steel production factories, oil & gas...) in 29 countries. Cresco's research & development team has patented the ARMADILLO™ technology. For further info: www.cresco-group.com

Q: Have any ARMADILLO™ 500R foundations been consented by the Christchurch City Council?

A: Yes

Q: By choosing an ARMADILLO™ 500R foundation may I do without soil improvement or piling works?

A: Generally you can. Only where the ground is prone to static settlements under load some additional works might be recommended.

Q: How much does an ARMADILLO™ 500R cost per square meter?

A: The construction costs of an ARMADILLO™ 500R (as well as for any foundation) depend on several factors such as the architectural layout, the loads of the superstructure and the features of the ground. Saying that an ARMADILLO™ 500R generally is more cost effective than other solutions.

Q: I don't need a re-levelleable foundation, is the ARMADILLO™ 500R convenient in other applications?

A: Yes, it is. Every time a strong and stiff shallow base is required the ARMADILLO™ 500R is extremely competitive. Where the re-levelleability is a not required performance the ARMADILLO™ 500R does not include the ARMADILLO™ Jacking Pads 250. By taking advantage to his structural performances you can get a safer base or you can reduce other costs such as: piling (e.g. by reducing their number) or soil improvement works (e.g. by reducing their depth and/or their extension).

Q: Can an ARMADILLO™ 500R foundation be used on deep piles?

A: Yes, either as a re-levelleable type (e.g. substituting the ARMADILLO™ Jacking Pads) or as a simple stiff base (e.g. to reduce the number of piles and provide extra structural strength to the base).

Q: Can the use of an ARMADILLO™ 500R reduce my costs for ground improvement works?

A: Yes, it can. Both the ground improvement depth and extent can be reduced (because the ARMADILLO™ 500R can accommodate large differential settlements and support the entire load off the external footings).

Q: I would like to substitute an existing ring beam foundation type with an ARMADILLO™ 500R, can I maintain the timber floor?

A: Yes, you can. The timber floor can be placed on top of your new ARMADILLO™ 500R. Specific details have been designed for this purpose.

Q: The ARMADILLO™ 500R does not contain polystyrene, how can it ensure such a good thermal efficiency?

A: The ARMADILLO™ 500R exceeds the building code when the ARMADILLO™ Thermal Bases are used and anyway it complies with it when they are not used. In this latter case the ARMADILLO™ 500R thermal efficiency relies on the reflective properties of the ARMADILLO™ Thermal Bases combined with the air pockets spread throughout the foundation.

Q: How long does it take to re-level a house with an ARMADILLO™ 500R foundation?

A: The re-levelling and repair (including any associated superstructure damage) can be completed within a 4-week period during which the occupants may have to be relocated. We consider a period of 2 weeks to be sufficient for most of cases though.

Copyright © 2015 – ARMADILLO, Bang and their logos are trademarks. All right reserved.

NOTE: This information is given in good faith being based on the latest knowledge known to Bang Ltd. Whilst every effort has been made to ensure the contents of the publication are current while going to press, customers are advised that products, techniques and Codes of Practice are under constant review and liable to change without notice. Up to date information is available from our Technical Services Department on request. Responsibility cannot be accepted for the application of products, and no claims can be considered, where the manufacturer's instructions have not been followed. The user should not assume; based on information provided in this sheet, that the product is suitable for any abnormal use. All products are sold subject to our standard conditions of sale, available on request.

This manual can be revised without notice. Ask for the latest issue at info@bang-international.com

ENDNOTES

- 1 Depending on the ground conditions
- 2 See the chapter "Site works: re-levelling"
- 3 Houses with a regular rectangular shape and area of approximately 230 sqm
- 4 The estimate refers to the installing of the ARMADILLO™ pods 500, the ARMADILLO™ Keystones and of the slab internal reinforcing
- 5 The ARMADILLO™ Foundation System is a specifically designed structure that must be calculated or peer reviewed by CRESCO GROUP

Distributed in New Zealand by



BANG

Bang Ltd. – 290 Clyde Road
Christchurch, New Zealand
info@bang-international.com
www.bang-international.com